

SPECIAL FEATURE

OIC TODAY

Business &
Investment
Magazine

READERS OF TODAY LEADERS OF TOMORROW



INTEGRATING TECHNOLOGY TO PRESERVE PUBLIC HEALTH

MR LEONARD D'CRUZ, FOUNDER AND MANAGING DIRECTOR AND
DATUK DR M SHIMI, DIRECTOR OF SOMA HEALS (SM) AND
THE INTERNATIONAL MARKETING DIRECTOR

SOMA MEDICAL SDN BHD

A COMPANY COMMITTED TO ADVANCING INDOOR AIR QUALITY

Soma Medical Sdn Bhd and Soma Heals (SM) Sdn Bhd (collectively known as “Soma Group”) have more than a decade of experience in developing Indoor Air Quality (IAQ) infection-control and surface decontamination solution protocols for hospitals, food processing plants, offices and schools.

We aim to create awareness and promote the prevention and mitigation from cross contamination infections, based on the basic principle of hygiene. As such, our products are developed to improve the quality of health and life.

Soma Group’s unique technology offers support to mitigate bacteria, yeast, mold, fungi and viruses in air, surface, and water environments, thus controlling infections like Carbapenem-Resistant Acinetobacter Baumannii (CRAB), Escherichia Coli (E. Coli), Methicillin-Resistant Staphylococcus Aureus (MRSA), Norovirus, SARS, Swine Flu and now with the advent of Covid-19.

This technology – advocated by the Centres for Disease Control and Prevention, USA (CDC) and the Environmental Protection Agency, USA (EPA) and employed in our core products – involves Ultra Violet-C (UV-C) light, SM Nano 1152 titanium dioxide, active carbon, negative ions, and High-Efficiency Particulate Air (HEPA) filters, all working in unison.

Our consultancy services are available for customers to transform their processes and procedures to address the threat of superbugs. Our sterilisation and decontamination philosophy focuses on basic cleaning, involving both the mechanical removal of pathogens and dissolution of bio-film using minimal levels of detergent and disinfectant.

The Soma Group team comprises experienced infection control consultants who assist healthcare professionals to protect patients and themselves from infection in a credible and cost-efficient manner.



FOUNDER	Allahyarham Dato’ Dr Raja Mohamad Abdullah
ADVISORS	Dr El Hassane Hzaine Commissioner General of OIC Mission to Dubai Expo Professor Emeritus Tan Sri Anuwar Ali Renowned economist and exponent of higher education Professor Sultan T. Abu-Orabi Secretary General of the Association of Arab Universities
CHIEF EXECUTIVE OFFICER	Mr Muhammad Raja Talib bin Dato’ Dr Raja Mohamad Abdullah
EDITOR-IN-CHIEF	Dr Raja Laila Rani binti Dato’ Dr Raja Mohamad Abdullah
EDITORIAL COMMITTEE	Mohanad Alnajjar Natasha Senieur
MARKETING DEPARTMENT	Izian Izzaty - izian@oictoday.biz Farah - farah@oictoday.biz Zulhili - zul@oictoday.biz
MULTIMEDIA	Sayd Haque Md Saidur Rahman
PUBLISHER	NM-TRLA PUBLISHING (M) Sdn Bhd (440525-P)
	OIC INTERNATIONAL BUSINESS CENTRE (766614-D) Suite 1A, Level 24, Menara TH Selborn, 153 Jalan Tun Razak, 50400 Kuala Lumpur, Malaysia. Tel: 603-2681 0037 Fax: 603-2681 0032 Email: info@oictoday.biz Website: www.oictoday.biz

OICTODAY Business & Investment Magazine
READERS OF TODAY LEADERS OF TOMORROW

IN COOPERATION & ADVISORY BODIES

 ISLAMIC CENTRE FOR DEVELOPMENT OF TRADE (ICDT)  ORGANIZATION OF THE ISLAMIC CONFERENCE (OIC)

SUPPORTED BY

 ASSOCIATION OF ARAB UNIVERSITIES  ASSOCIATION OF MUSLIM WORLD BUSINESS, MALAYSIA

 FEDERATION OF ARAB BUSINESSMEN  ISLAMIC CHAMBER OF COMMERCE KUALA LUMPUR

JOINT COLLABORATION WITH

 RAMCEL MEDIA

LIVING AND WORKING WITH COVID-19

By Dermott Reilly, CEO of Ingeniatouch Ltd & NanoLandGlobal Ltd

In regard to living and working with Covid -19, it appears that air quality and safe touch points are essential. We can't stop Covid, we can only slow it down, and as the virus forever mutates, we can only play catch-up to mitigate its long-term impact on society.

Most scientists agree the focus now is management of Covid respiratory droplets, aerosols and where possible internal environments. UV Light has an essential role to play here and is a major tool in the battle to create sterile and safe home and work environments. Surface hygiene and safety are obvious strategies in infection control, but flexible UV light systems that enable pathogen-free air, that can eradicate Covid aerosols that are airborne for long periods of time and travel via HVAC and / or airflows directly into the human trachea, are essential tools to enable society to reopen and return to the new normal: living and working with the disease.

Humidity is a key factor here too, but if one looks at working with Covid in the hospitality sector, for example, customers will only return to pubs, restaurants and hotels if:

- Clients feel safe and secure.
- Facilities are not empty: devoid of life-buzz.
- Environments are warm and cosy in winter months and cool in summer.
- Businesses are profitable.

So how does one address the potential spread of Covid aerosols from a carrier in a warm and busy convivial restaurant? Again, UV light offers the ideal solution, together with advanced microbiota barrier surface coatings.



Turning a negative into a positive is always a good. A global pandemic can help accelerate change. Necessity is the mother of invention. We have the possibility now to remove a lot of aggressive, toxic cleaning chemicals deployed in abundance across every area of property management, schools, work and home life, which sadly drives higher cancer levels and creates superbugs and premature death in our healthcare systems. We now have alternative safe and sterile coatings that enable a bacteria static environment for much longer periods of time: six months and more.

Going forward with sustainable and clean label hygiene protocols we see facilities been better managed, deploying nanotechnology and electromagnetic wavelength to resonate with nanoparticles that can attach to coronavirus receptors. Indeed, bacteria and viruses are key to cell life. Enabling balance is what is important and as we identify and unlock the electromagnetic codes to switch on and off specific bacteria and viruses, we can again help fight disease and create a much more healthier and safe environments of our children and their futures.

UVGI LEO-6 AIR STERILIZER

Model: LEO 6
 Lightwave: UV-C primarily in the 253.7nm wavelength
 Power: AC220-230V,50Hz
 UV intensity inside the chamber: 15,000 $\mu\text{w}/\text{cm}^2$
 Bulb lifespan: 8 000 operational hours
 Ballast lifespan: 20 000 operational hours
 Bulb length: 217mm
 Power of bulb: 18 watts amalgam
 Negative ions: 2 millions/cc
 PCO plate inside coated with SM nano 1152 TiO₂
 PP plasma filter
 Effective area: 30 square meters
 Net weight: 2.5 kgs
 Built-in suction fan with pilot light
 indicating when UV-C lamp needs to be replaced



Structural Representation and Schematic Diagram of the LEO-6

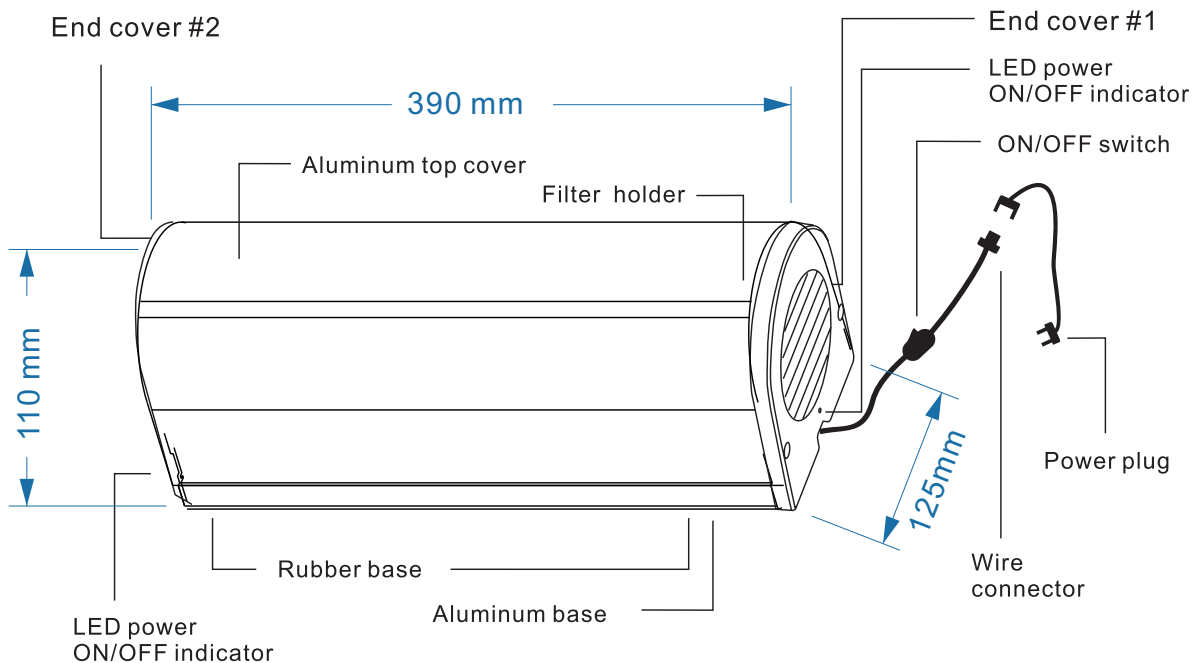

The best way to mitigate against airborne viruses, yeast, fungi, bacteria and mold

UVGI LEO-6

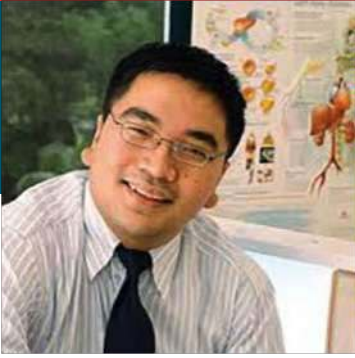

FAR-UVC LIGHT AND INDOOR DISINFECTION

By Dr Azam B Mohd Nor, Paediatrician/
Paediatric Cardiologist at PHKL

The Covid-19 pandemic raging across the world in 2020 has highlighted the risk of airborne invisible viruses. Beyond the current dogma of social distancing and wearing a mask in public, are there any additional solutions to reduce the risk of infection?

Devices emitting far-UVC light might be an excellent candidate. A study conducted by the Vagelos College of Physicians and Surgeons at Columbia University Irving Medical Centre found that "more than 99.9% of seasonal coronaviruses present in airborne droplets were killed when exposed to a particular wavelength of ultraviolet light that is safe to use around humans."

This means that UVC light of a certain wavelength can be used to kill viruses without harming human skin. That makes it safe to use at home or at the office.

Just how quickly does UVC light eliminate airborne viruses? It turns out, mere minutes. The study estimates that "continuous exposure to far-UVC light at the current regulatory limit would kill 90% of airborne viruses in about 8 minutes, 95% in about 11 minutes, 99% in about 16 minutes, and 99.9% in about 25 minutes."

The study concludes that "the sensitivity of the coronaviruses to far-UVC light suggests that it may be feasible and safe to use overhead far-UVC lamps in occupied indoor public places to markedly reduce the risk of person-to-person transmission of coronaviruses, as well as other viruses such as influenza."

This means that far-UVC light devices may provide new ammunition in the battle against hidden viruses and bacterium. We will likely see more and more of these devices being used in home and clinical settings.

More research still needs to be done to establish just how these devices affect infection rates and clinical outcomes, but existing research is promising. In the future, we just might live in a world where the risk of hidden viruses and bacterias can be greatly reduced thanks to innovative technologies such as these.

In the local setup there are many medical and dental institutions adapting the use of UVC devices to mitigate infection.



THE ROLE OF IAQ IN DENTISTRY

By Dr Yogesh Sharma

The prevalence of cross contamination in the hospital environment has become a very important and serious matter. In the recent events of super bug outbreaks and increase in hospital acquired infections, we are faced with difficult moments that puts our future at jeopardy. Many patients are at risk of contracting hospital acquired infections despite of the serious infection control measures implemented by the government and healthcare authorities.

In a dental facility, hundreds of patients are treated every day from different countries, lifestyles and sociodemographic backgrounds. The nature of the job requires us to be in close proximity with our patients all the time. We are constantly at risk of being exposed to pathogens from our regular dental procedure due to aerosolization in a close environment. The spread of infectious air borne disease in a closed air-conditioned environment such as a dental clinic could prove to be critically serious. It could spread via direct air inhalation, patients sneezing or coughing, and evaporation of the infected droplets into air usually during treatment. The infected particles introduced in the dental environment could potentially contaminate the wall, ceiling and the dental chair in the room. But it does not stop there, as these infected particles can further spread from one surgery room to other areas within the clinic via air-conditioning circulation, negative pressure, air vents, or the patient and dentist himself; similar to the "sick building syndrome".

On average, we breath about 7 to 8 litres of air per minute, 166 gallons of air in an hour, 24,000 breaths in 24 hours... in TOTAL giving us around 12,000 litres of inhaled air per day! In a closed environment, we are constantly sharing this air with other people. Studies indicates that about 70 % of the patients treated by healthcare professionals aren't aware of their underlying medical conditions. That puts us in a very vulnerable state not knowing how safe is the air around us that we are breathing. By using IAQ technology, we are able to help

curb cross contamination via UVC ray in combination with TiO2 and negative ions in a dental vicinity. The efficacy of this technology also allows us to decontaminate surfaces that have been exposed to virulent organisms such as SARS, H1N1, tuberculosis and MRSA.

As a director and IAQ Dental Consultant, it is my responsibility to inculcate and integrate indoor air quality in a dental environment. It's vital that we work in a healthy habitat breathing air that is free from contaminants. This is important to help prevent post-operative complications after dental treatment. Contaminated air in the clinic could introduced bacteria into open wounds during surgical procedures such as wisdom tooth removal, implant placement, sinus lift procedures, harvesting PRF- Platlet rich fibrin, and minor surgical manoeuvres. The quality of the air inside a dental clinic could influence the outcome of many dental procedures, in terms of success rate of the treatment.

As part of Soma Medical Research and Development team, we have engineered new methods and devices that follows the CDC guidelines to help decontaminate the air in a closed environment. These new developments and inventions pioneered by Mr. Leonard D'Cruz is a joint venture in our vision to create a healthy environment for healthcare workers. Together we design products to treat contaminated air which are currently used by the local government and private hospitals in Malaysia. Many dental clinics have used our technology to enhance the infection control protocol on a daily basis. Our hope is to create awareness on the importance of Indoor Air Quality in a working environment among dentists and all other healthcare workers around the world.



INTEGRATING TECHNOLOGY TO PRESERVE PUBLIC HEALTH

AN INTERVIEW WITH

MR LEONARD D'CRUZ, FOUNDER AND MANAGING DIRECTOR AND
DATUK DR M SHIMI, DIRECTOR OF SOMA HEALS (SM) AND
THE INTERNATIONAL MARKETING DIRECTOR

SOMA MEDICAL SDN BHD

Soma Medical Sdn Bhd was founded in 2002 by Mr Leonard who is also the Managing Director of the company. The word *soma* in Greek means body. So, the company name essentially refers to its mission of protecting the body against external germs. Mr Leonard and his team have created a number of products over the last 18 years. During this period, he gained partners of interest not only because of COVID-19, but also to combat other viruses. The company has the innovative technology that differentiates their products from others. Datuk Dr Shimi steered the company to branch out and establish Soma Heals Sdn Bhd, which is the international marketing arm of the company.

An Unexpected Path

Mr Leonard received a diploma in civil engineering in 1986. It was a difficult time because of the recession and employment was low. He did some civil engineering work and eventually joined a medical company that utilised lasers for surgery. It was something new he had to learn, and he went for training in London. This sparked his interest in medical equipment and the medical industry.

As he talked about the beginning of his journey, Mr Leonard remembered meeting a professor and allergy specialist who told him that no body at that time was looking into mitigating indoor cross-contamination in a hospital environment. "At most, people bought air purifiers, but it was not addressing the problem," he said. Hospitals were having significant problems with post-operation infections and cross-contamination. It is not uncommon for people go into the hospital with a simple cough and come back with Methicillin-resistant *Staphylococcus aureus* (MRSA) and other serious infections. The business happened purely by accident Mr Leonard remembers. "It was over a dinner when I was told that nobody is looking into advanced technologies at the moment, while indoor contamination caused a lot of problem to people and when I went back to my home I said maybe I could do something here."

He decided to take up a certification in indoor air quality, which led him to getting certified as an indoor environmentalist by Indoor Sciences in the U.S. He said, "From there I started reading about the technologies advocated by the Environmental Protection Agency (EPA) and the Centers for Disease Control and Prevention (CDC). According to the CDC, you need five technologies to work in unison to combat cross-contamination: High-Efficiency Particulate Air (HEPA) filtration, active carbon, titanium dioxide, UV lights and negative ions."

He went on to bring together a team to design products that use these five technologies. The goal was either one product that has all five of them, or individual products that are technology

based and collectively they can solve the problems of contamination in indoor environments. Mr Leonard mentioned that, "In the course of designing these products, together with my team, we got a factory in China and I started to realise that UV-C and titanium dioxide do help tremendously in the mitigation of COVID-19 and any influenza. I am saying COVID-19 here because it is the topic everyone is talking about nowadays, but it also encompasses SARS." When this is used in unison with the others, an Indoor Air Quality Solution Protocol is established and this is the ultimate goal.

Technology and Products

All the products are designed and produced in-house, and Mr Leonard illustrated the process of how each product is developed. The team also participates in exhibitions to look at products developed by other companies overseas. This allows them to investigate their cost factor. Then the design team integrates an innovative solution to the idea in order to develop a product that does exactly the same thing, or even more, at nearly half the cost. Essentially, Soma Medical develops generic products. Mr Leonard mentioned that, "For the UVGI SM 20, the Americans and Germans have got their versions and it's very expensive. However, our price is competitive."

"There is not a single company in Malaysia and even Southeast Asia doing this. No one provides all five solutions as recommended by EPA and CDC except Soma Medical," he remarked. Soma Medical has a device that combines all five technologies and they have other devices, each of which offers solutions using only one of the technologies. The reason for this is to have a wider flexibility and range of options in addressing clients' needs. For example, if a client says their place is just contaminated with COVID-19 then they do not need to take an air purifier, because it is not going to solve the problem.

In addition to following all safety instructions by the CDC and EPA, Soma Medical uses RF and motion sensors to provide extra care and additional comfort to its clients.

COVID-19 is not only airborne, it contaminates surfaces as well. Hence, when Soma Medical comes in to offer a solution, they can either treat the place with titanium dioxide or they can bombard the entire place with a very high level of UV light, that is the big one you see out there. Mr Leonard said that, "Basically we push the machine in there, we set the timer for 10 minutes and within this time it destroys all viruses in the area. I am talking about those in the

air and on surfaces. Then we move it to the next area. It has wheels and can be easily moved between rooms."

That is addressing the immediate problem with decontamination on the spot. To mitigate cross-contamination over a long period of time, Soma Medical has UV lights to fix on the walls, and the LEO-6 device can be set up on a table. With these machines, if an infected person walks into a room without a mask, everyone is still protected. "Every product has got a unique use by itself, sometimes they work independently, sometimes they work in unison. It all depends on the problem and how it should be solved," said Mr Leonard.

Soma Medical has two types of UV equipment: exposed UV where you can literally see the light and concealed UV, which is made for an indoor environment with people being around it. Exposed UV cannot be used around people. To enhance safety measures, the equipment has sensors: RF sensors and motion sensors following EPA guidelines. The moment someone comes near the danger zone, the machine will automatically shut down for safety. The moment that person walks away, it turns on again. The company is following all the parameters given by the safety guidelines as far as UV radiation is concerned. They advocate that the only UV that is completely safe is a concealed one.

Mr Leonard said, "Now we have gone one step ahead, the normal UV uses 253.7 nanometres wavelength and it is called germicidal wavelength and it is used in most devices that are available in the market to destroy viruses, bacteria, etc. The latest studies that came out just before the pandemic suggest the use of 222 nanometres wavelength and that is much safer." In spite of it being safe enough to even stand next to, they still utilise the remote sensors because it is a normal psychological response for people to feel uneasy and concerned about their health when they see the blue light. He remarked that "people think they may get cancer so we prefer to use the sensors to automatically shut down the machine so people will not worry."

It can be hard to break public opinion or fears. Datuk Dr Shimi explained that home microwaves are more dangerous than the UV light because people heat plastic materials which retain that radiation as they remove it from the microwave. She said that, "The microwave is definitely not safe and it is much more likely to cause cancer compared to our products because ours use only 222 nanometres wavelength."

In the concealed UV device, the radiation cannot escape out of the machine. It works by way of a suctioning the air surrounding it. The air is sucked in, cleaned or disinfected and then sent back



out to the room. The machine comes in a large size and also a smaller, less expensive size that can be carried from one room to another. In a room it just needs to be turned on for 15 minutes. This applies to any room whether an office, a conference room, a hotel room, a medical clinic or any type of indoor environment.

One of Soma Medical's latest products that came out three months ago and is made for use in the car. Mr Leonard says that Myanmar alone ordered 1,000 pieces of this product because they wanted it in every public transport vehicle. It uses USB cable and has a sensor. What makes it unique is that it has a very high level of filtration that is replaced quarterly. It is a simple device but very smart. The sensor tells the user whether the room is contaminated by turning red in colour and using a 222-nanometre wavelength it spins faster until the contamination level goes down and then it turns green.

Customised Solutions for Care

Mr Leonard stated that, "When we go to meet a client, we do not talk about selling of our equipment. The client tells us I got this problem: A, B, C, D and we tell them in order to solve this problem you need to do A, B, C, and D. We are solution providers. We are not only selling equipment to clients." Their approach when a client explains their problem is to not only give the solution but also explain the details about how it works. Clients need to understand how the decontamination process works and they have many questions too.

The company's developments are for individual and commercial use as they aim to consider all environments where such technology can make a difference. Soma Medical is also able to customise a solution for clients who require it. For a client needing solutions for a 50-storey building they would be looking at high expenses. Mr Leonard said that the company can install the UV lights inside the air-conditioning system and that would be a cheaper solution. Every

floor has an Air Handling Unit (AHU) for the entire floor and the UV lights are installed in the AHU so the entire office or floor gets decontaminated.

Another reason that Soma Medical offers various products is because for large buildings whole floors can be occupied by different tenants who may not all want the same solution. This is exemplified in the option to install a device in the AHU that covers the entire floor versus using one designed for a single room or office. "Basically, different products and protocols are given based on the clients' needs. We have done a lot of customisation work, a lot," said Mr Leonard.

As international reports state that nearly 30% of buildings suffer from 'sick building syndrome' the LEO-3 from Soma Medical addresses this issue to make buildings safer for people against air borne contamination.

"Money is important, and we need it in order to sustain. But equally important is our goal that we really want to make a difference. I feel very proud when I walk into a hospital and I see my product on the wall, or on the table," said Mr Leonard. Datuk Dr Shimi highlighted a personal story that her sister was hospitalised with a diabetic wound and ended up contracting MRSA at the hospital. She said because of that, "The family had to take her to a specialised hospital to treat that together with the diabetic wound. I started to install this device in her room in the private hospital and then she is the fastest to be out." She also shared that it took some time for their families to understand the benefits of the products but now her 86 year old mother sleeps with this device in her room, and her two year old and 1.5 month old grandchildren are sleeping

with it too. "That is how safe this product is," she reassured.

Previously when someone visited a dental office, the practitioners were only concerned whether they were diabetic or have high blood pressure, which can have implications for dental procedures. Now, dental clinics are also concerned about communicable diseases. "They do it because they are afraid of contracting anything. That is why when we have these products in a closed environment, they make a big difference and we usually do pre and post evaluation before and after we run the equipment to see how efficient they are to improve the indoor air quality."

Mr Leonard mentioned that there are certain things that can or cannot be done, citing aircrafts as a complicated example. "You can put something to decontaminate the plane once it lands, but you cannot put anything on board as it takes off, because for this you need CDC approval and the Department of Civil Aviation (DCA) approval and they are very strict about giving approvals because it is very sensitive. It may take many million dollars before the permission is finally granted."

Many people may not know that above 28,000 feet the scrubber in the air eliminates all kinds of germs, viruses or bacteria, he added. The problem arises in the waiting area when you are boarding the aircraft, and somebody nearby may be COVID-19 positive. Mr Leonard said, "Above 28,000 feet, you can take off your mask and do not have to worry. The precaution needs to be taken before entering the plane. That is why we recommend LEO-5 in the waiting area." He emphasised that all the information is based on scientific evidence.

Continuing on detailing elements of contamination he also mentioned that a single infected person in a lift can contaminate 72 people, and one person in a prison can infect 500 people with COVID-19. Such an incident did happen in Sabah, East of Malaysia. "It is not something to be taken lightly," he stressed. "That is why I do not use the word 'kill', because it is almost impossible to kill those viruses completely even using our products. But can they mitigate the impact? Yes definitely, and we have a hospital that recently installed our LEO-5 in their lifts."

International Expansion

The company is focusing their international expansion into three different regions to explore new markets, some of which have have most of the OIC countries including the Middle East, Africa, and Central Asia. Mr Leonard is managing expansion in India, Myanmar and Thailand. Simultaneously, Datuk Dr Shimi manages the international expansion in other parts of the world

such as Africa, Europe, Latin America. For the Middle East region, one of Soma Medical directors, Elaraf Guma Otman, has been leading the efforts to introduce Soma Medical's products and manage the enquires from potential clients and partners. Dr Otman is a subject matter expert who has a Ph.D. in healthcare and nanotechnology applications.

Datuk Dr Shimi says she considers the task quite easy due to her experience with international markets and the medical field. She said, "I saw an opportunity in working with Soma Medical, I came in immediately and bought the rights and started working through my pharmaceutical establishments." Mr Leonard and Dr Otman have worked together diligently to be able to clearly explain their products and client solutions across language barriers. Due to his fluency in the Arabic language, being a Libyan national, and excellent communication skills and knowledge of the culture and lifestyle of people in the Middle East, Dr Otman handles all enquiries from the Middle East market, in addition to his tireless work to develop new innovative solutions.

Datuk Dr Shimi's pharmaceutical establishments encompass the African continent, Europe in addition to parts of South, Southeast and Central Asia. Her main market is Vietnam, and she has been there for 26 years. "I have developed a factory there, so I have a lot of experience in that region and have developed excellent relationships with suppliers and retailers." She also has experience in many of the European countries.

The Director of Soma Medical's international marketing programmes said, "Our biggest market today is Africa, which I have developed. I took it to a different level; I did not look only at hospitals. At this point of time during the pandemic, I looked at supplying our products to schools, offices, refugee centres among many other places and we have started developing that way." The response and interest across Africa have been significant, especially in considering how they plan to protect kindergarten and school students. Inside a classroom with children, social distancing is very difficult. The UV light device is the easiest way to make the classrooms safe so the children can be free in the classroom and the teachers and parents don't need to worry, Datuk Dr Shimi explained.

Affordability remains one of the differentiating factors of Soma Medical innovative products as well. The company wants their products to be accessible financially. Mr Leonard said, "We made big devices for the big boys, and we made small devices for other people to buy at reasonable prices."

Their products are in the market now and they receive orders every day from the Middle East and Arab countries. "Somebody wants to buy for the home, somebody wants to buy for the office, for the clinic, and for the car," he detailed.

Awareness and Consultancy

Soma Medical provides awareness through presentations about their solutions and how they can help in various settings. They highlight how much awareness is lacking. "While there are so many factors and methods implemented to mitigate cross infection, airborne is still the toughest to deal with. You can spray and wipe the table multiple times, but it is not easy to mitigate airborne harmful particles. There is a big gap between the awareness of the benefits indoor air quality products offer and the readiness of various groups to actually use them at various levels."

For example, Mr Leonard states that many people don't know the importance of something as simple as having a humidity metre in a hospital. "The recommended humidity is 40-60 Rh. If it is below 40 Rh there is a whole cluster of problems you are going to have from bacteria to mould," he said. "If you are not controlling this, how are you going to control other things in the environment? Sometimes when we do presentations in hospitals, nurses are surprised and ask questions about this. I have been in a room full of brilliant surgeons, but when it comes to this topic they are quiet, and being quiet to me means they do not understand!"

The Soma Medical team has noticed an appreciation people have that the company is addressing these issues and talking about the mitigation of problems using EPA and CDC standards. In addition, people are very receptive to what they have to say. While it may be new information, people are keen to learn. Due to this receptive attitude across the board, and due to the satisfaction of clients, the company doesn't do a lot of advertising. Mr Leonard asserted that, "I work purely on reference. I do one hospital, and that hospital goes and tells another hospital, so I know that there is a demand for this." Additionally, the company never received assistance from the government or even took out a bank loan.

The Managing Director explained that their advertising is focused and on a small scale due to a few reasons. First, he is hesitant to bring someone on board too quickly and without careful examination, as the work requires a high level of responsibility. Finding the right person for production and marketing is crucial to avoid any dangerous situation. Second, they want to focus their resources on critical projects involving

big clients that deal with a high volume of people and need access to the technology more urgently.

Third is that Soma Medical current policy opposes internet-based companies to market its products on their platforms. Mr Leonard stated that, "My products are made for a good purpose to serve a real purpose. Nobody is going to put it online just to get more sales, no way." That perspective rings true for everyone in the company. It is the company's objective not to just go out and make a big sale, but to create awareness and resolve problems. They have completed projects and are proud to highlight that until today not one of them has had a single positive case of COVID-19, even in some of the red zone areas.

Future Strategies

Over the past 18 years the company has evolved significantly. Soma Medical now has different products to solve different problems. They have come very far from the first prototype of the first generation. One consideration going forward is that modern day viruses continuously mutate and gain strength. Due to this, using UV light that is working at 5 watts won't be effective. Mr Leonard said now we need something working on 16 watts or 18 watts to address the new strain of viruses.

While he is unsure of what the future holds, the company's founder hopes that the understanding and acceptance of such technology and products will grow exponentially. Verbalising our feelings of the new normal, he commented, "Have you noticed nowadays if you leave your car and forgot to put on your mask you feel so strange?" Datuk Dr Shimi said that she wishes every household will have a LEO-6.

Another point the partners reiterated is the damaging aftereffects many COVID-19 patients experience. For those that don't die in the hospital of the virus, many will go home to face debilitating, and often fatal, side effects such as heart attacks, brain damage and dementia. This often-understated fact is why such technologies not only fight against viruses but protect people from the horrible effects faced after recovery. Soma Medical has gained the trust of not only clients but also the authorities that text its products for safety and quality assurance. In Malaysia, for example, the SGS is the body responsible for issuing approvals to market certain products after they are tested. Mr Leonard stated that the SGS is very familiar with the quality of their products in the sense that it recommends them for the use of multinational companies in Kuala Lumpur to ensure indoor air quality. Leveraging these advantages, Soma Medical is expected to grow further and reach far beyond its current markets.

من منتجات صوما ميديكال مصباح ليو3 ذات الأشعة فوق البنفسجية القاتلة للجراثيم (UVGI/LEO3)

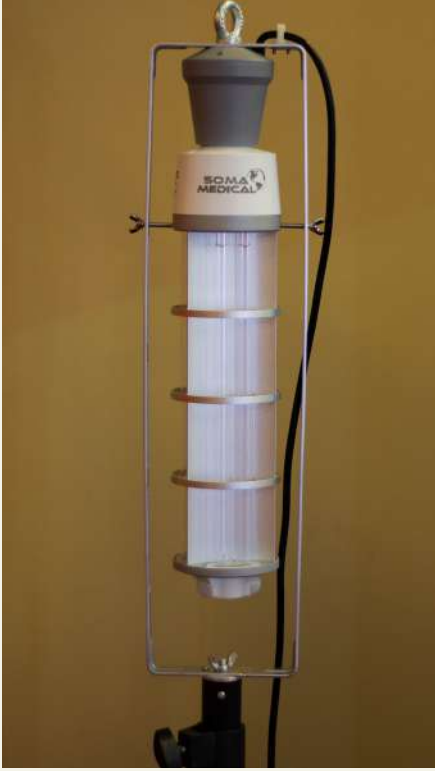

فوائد الجهاز:

- مؤثر لمنع السل والانفلونزا والعدوى المقاومة والعدوى الأخرى المنتشرة.
- يقضي على 99.9% من البكتيريا والفيروسات والجراثيم الموجودة في المستشفيات والمدارس والمصانع والمكاتب.
- يوصى به من قبل الخبراء الطبيين.
- يقضي على البكتيريا والفيروسات في الأماكن المغلقة.
- يقلل من حساسية الصدر.
- يقضي على الروائح في الجو ويجعله نظيفا.

أين يستعمل وكيف يتم تركيبه؟

- يركب داخل نظام التكييف المركزي.
- يستعمل في المستشفيات والعيادات وعيادات الأسنان والمدارس ومرافق الإيواء.
- يستعمل في مصانع ومحازن الأغذية (الجبن - الفاكهة - الخضروات - اللحم - وغيرها).
- يستعمل في المعامل والأماكن التي تحتاج الى هواء نقي.
- يستعمل في الاماكن الصناعية بصفة عامة لمنع التلوث ومنع الروائح الناتجة عن ذلك.

تركيب الجهاز وخصائصه:

- الطول الموجي للأشعة المستعملة: 253.7 نانومتر.
- شدة الأشعة 1 متر: 60.000 ميكرويف/سم.
- عمر المصباح: 800 ساعة تشغيل.
- عمر القطب: 2,000 ساعة تشغيل.
- طول المصباح: 217 سم.
- قوة المصباح: 20 وات.
- الفولت الكهربائي: 220 - 230 فولت.
- السعة الكهربائية: 50 هيرتز.
- كمية التأثير: 200 قدم مكعب في الثانية.
- به حفاز ضوئي مؤكسد.
- له إطار من الألمنيوم.
- يمكن استعمال الأزون كاختيار.
- يتم تركيبه في داخل قنوات التكييف.
- أبعاد الجهاز: 29.5x16.0x21.5 بوصة.
- وزن الجهاز 1.35 كجم.
- التعبئة: غلاف كرتوني داخلي 31.0x18.5x23.0 بوصة.
- كرتون 6 أغلفة 58.0x32.0x48.0 بوصة.
- الوزن الثابت: 13 كجم. الوزن الكلي: 18 كجم.

ما الذي تستطيع الأشعة فوق البنفسجية (ج) فعله؟

- تؤكد البراهين العلمية أن الفيروسات والميكروبات المقاومة والأنفلونزا وكولوستريدم ديفسلي واشينوبكتاريومان وغيرها تنتقل عبر الأسطح البيئية الملوثة وتشير الدراسات أيضا إلى أن 50% فقط من الأسطح الموجودة داخل حجرة العمليات أو حجرة العناية في المستشفيات مطهرة.
- ومن الممكن أن يكون خطر انتقال العدوى عن طريق الأسطح الملوثة الى مريض آخر وذلك نتيجة مريض سابق كان في نفس الحجرة. ولذلك فإن الأشعة فوق البنفسجية (ج) المتنقلة تقلل من عدد المستعمرات الجرثومية الأكسجينية وكولوستريدم فيسلي من على الأسطح الملوثة في المستشفيات.
- بالإضافة إلى استخدام الأشعة فوق البنفسجية (ج) في تعقيم المستشفيات، فإنها تستعمل في تعقيم المنازل من التلوث الميكروبي حيث إنها تقضي على غبار العث وبق الفراش عند الإستعمال الدوري لها وتمنع تلوث الهواء الناتج من البكتريا والفطريات.
- كما يستخدم جهاز الأشعة فوق البنفسجية (ج) الذاتي المتحرك لمنع التلوث في حجرات المرضى والنادق والمكاتب والمكاتب المغلقة. ويمكن استعمال أجهزة الأشعة ذات الموجات القصيرة في تعقيم المياه والغذاء بالإضافة إلى استعمالات أخرى مختلفة منها تعقيم مياه الشرب و مياه الصرف الصحي و تنقية الهواء.

والخلاصة ان الأشعة فوق البنفسجية (ج) تقضي على الميكروبات الدقيقة والجراثيم وذلك بإتلاف الحمض الأميني DNA للخلية.

للاستفسار والحجز يمكنكم التواصل عبر المعلومات التالية:

هاتف رقم: 006011 2814 6173

بريد إلكتروني: otman_e2000@yahoo.com



د. العارف جمعة عثمان التائب

- استشاري وعضو مجلس الإدارة في شركة صوما ميديكال.
- لبيبي الجنسية وحاصل على درجة الدكتوراة من الولايات المتحدة الأمريكية عام 2003.
- لديه خبرة طويلة في مجال إدارة الأعمال والابتكارات العلمية المتعلقة بالمجال الطبي.

نبذة عن تقنية النانو وعلاقتها بالأشعة فوق البنفسجية

تقنية النانو موجودة منذ القدم ولكن لم تكن مُعرَّفة، حيث إنها كانت تُستعمل في دمج المعادن من السيليكا لصناعة الزجاج الملون، واستُعملت أيضاً في تلميع الفضة حيث كانت تُسخن إلى درجات حرارة عالية مما يؤدي إلى خروج ذرات الفضة على السطح فتصبح لامعة بَرّاقة وقوية. وكلمة نانو مشتقة من الإغريقية "نانوس" وتعني القزم.

تعريف تقنية النانو: هي معالجة المادة بأجهزة خاصة لإخراج ذرات المادة من الداخل إلى سطح المادة، وهي تعتمد على معيار النانو ويساوي جزء من المليار من المتر. يمكن تبسيط الحجم تقريباً بمثال على ذلك حجم شعرة الرأس مائة ألف نانومتر، وحجم خلية الدم الحمراء 2,000 نانومتر، وحجم أصغر أنواع البكتيريا 200 نانومتر، وحجم فايروس جائحة كورونا 125 نانومتر.

استخدامات تقنية النانو: تُخصّص الكثير من الدول ميزانيات ضخمة للبحث في تقنية النانو حيث تدخل هذه التقنية في عدة صناعات منها:

- حفظ الأغذية، منتجات العناية بالبشرة، صناعة الطيران والكهرباء والصناعات العسكرية كأجهزة التصنت على العدو ومراقبته بصناعة حشرة نانوية بحاكيات مراقبة صغيرة جداً.
- كذلك يدخل النانو في صناعة الملابس حيث تكون هذه الملابس خفيفة وبإمكانها تغيير حرارة الجسم ولا تتسخ، وتساعد في إخفاء الشخص.
- تستخدم تقنية النانو أيضاً في توصيل الأدوية إلى العضو المصاب فقط (Nano Carries) والكشف على بعض المواد كالجلكوز أو الكشف عن الأمراض والبحث عن الخلايا السرطانية وتدميرها، وفي إصلاح الأنسجة وهو ما يسمى بالنانو المرهم.
- بالإضافة إلى ذلك، تستخدم تقنية النانو في القضاء على الجراثيم، لذا تُستعمل في تعقيم حجرات العمليات والعناية الفائقة وحجرات العزل الصحي والحجرات الخاصة بمرضى الرئوي وحساسية الصدر وجميع أنواع الحساسية، وتعقيم حجرات حديثي الولادة وحجرات كبار السن وغسيل الكلى وتعقيم الأماكن المغلقة مثل المكاتب والمدارس والمنازل وغيرها.

ونظراً لأن الأشعة فوق البنفسجية تسير في خطوط مستقيمة تحتاج في تركيزها على الأسطح لأربع دقائق تقريباً للقضاء على الميكروبات والفيروسات. لذا نستعمل في صوما ميديكال تقنية النانو وهي عبارة عن استخدام ثاني أكسيد التيتانيوم النانوي (SMT511) فعند تسليط الأشعة يحدث تحفيز ضوئي لجزيئات النانو ينتج عن ذلك أيونات سالبة وفضلات غير ضارة متكونة من الماء وثاني أكسيد الكربون فتخترق الأيونات السالبة جدار الخلية وتكسر الحامض الأميني (DNA) وبذلك يقضي على الخلية وتمنعها من التكاثر. ومن أجهزة صوما ميديكال التي تستعمل هذه التقنية معقم الهواء ICU200 ومعقم الهواء A565.

استخدام الأشعة فوق البنفسجية للقضاء على كوفيد-19

لقد وجد الباحثون الدليل الأول على أن الأشعة فوق البنفسجية (ج) بموجة طولها 222 نانومتر على أنها غير مضرّة للإنسان وفي نفس الوقت تقضي على فيروس سارس كوفيد-19. وتوضح دراسة من جامعة هيروشيما أن الباحثين استعملوا الأشعة فوق البنفسجية (ج) ذات الطول الموجي 222 نانومتر للقضاء على فيروس سارس كوفيد-19 بفاعلية دون الإضرار بصحة الإنسان، وهو البحث الأول من نوعه في العالم الذي يثبت في القضاء على كوفيد-19. وتوجد أبحاث أخرى تعرف بالأشعة فوق البنفسجية (ج) المتباعدة بموجة طولها 222 نانومتر ووجد أنها تقضي على الفيروسات الشبيهة بالكوفيد-19.

ومن خلال تجربة على الحاضن في جامعة هيروشيما وجد الباحثون أن 99.9% من سارس كوفيد-19 تم القضاء عليه وذلك بتعريض الفيروس لمدة 30 ثانية للأشعة البنفسجية (ج) بطول 222 نانومتر لمساحة 0.1م/م². تم نشر الدراسة في المجلة الأمريكية لمراقبة العدوى حيث تمت بطريقة أشويو 222 ذات العلامة المميزة باستعمال مصباح كريبتوكلوفايد بقوة سائل 100 ميكروليتر يحتوي على فيروس (ca. 5x10⁶ TCID₅₀/ML) وطرح على لوحة بوليسترين طولها 9سم. وترك ليجف في حاضنة بدرجة حرارة الغرفة قبل أن يوضع فوقه مصباح الأشعة فوق البنفسجية (ج) المتباعدة بطول 24سم.

الأشعة فوق البنفسجية (ج) ذات الطول الموجي 222 نانومتر تختلف عن تلك التي طولها الموجي 254 نانومتر حيث إن الأولى لا تخترق غشاء العين الغير حي ولا تخترق الجلد ولهذا فإنها لا تسبب أي ضرر للإنسان بعكس الأشعة فوق البنفسجية (ج) التي طول موجتها 254 نانومتر حيث يتوجب عدم تعرض الإنسان لها بشكل مباشر فهي تستعمل في تعقيم الأماكن التي لا يوجد فيها الأشخاص. أما بالنسبة للأشعة فوق البنفسجية (ج) 222 نانومتر فيمكن استعمالها بأمان في وجود الأشخاص أثناء التعقيم.

UVGI LEO 4 - AIR STERILIZER

Model: UVGI LEO-4
Lightwave: UV-C primarily in the 222nm wavelength
UV intensity @ 1 meter: 195,000 $\mu\text{w}/\text{cm}^2$
Bulb lifespan: 8,000 operational hours
Ballast lifespan: 20,000 operational hours
Power of bulb: 36 watts H-type * 2 pieces
EC fan: AC110V/220V, 0.10A
Fan speed: 2000rpm
Fan quantity: 2 pieces
Air flow rate: 28 CFM * 2
PCO plate: PCO plates coated with SM Nano 1152 TiO₂
Power of unit: 75 watts
Voltage: AC220-230V, 50Hz
Efficient area: 80 square meters

Product dimension: 110x220x860mm
Net weight: 4.80kgs

Packing information:
1 pc/inner carton: 170x280x910mm
2 pcs/outer carton: 360x320x920 mm
NW: 9.6 kgs GW: 14 kgs



Structural Representation and Schematic Diagram of the LEO-4

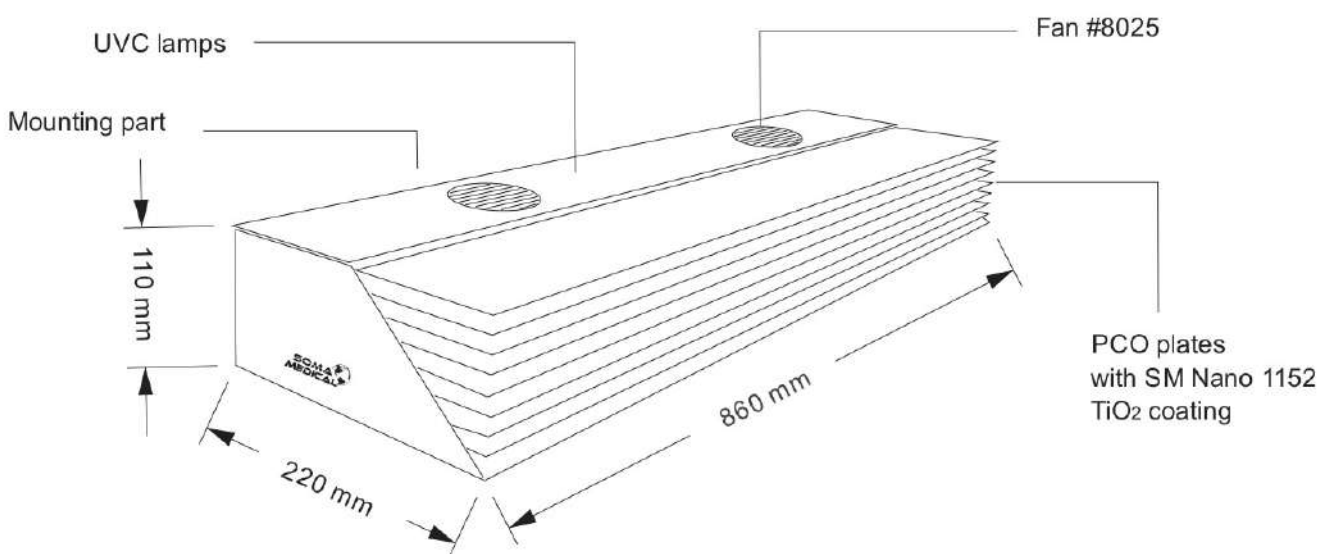

The best way to mitigate against airborne viruses, yeast, fungi, bacteria and mold

UVGI LEO-4