



## Ceiling UVGI System

- ▶ Deluxe intelligent ceiling UVGI system
- ▶ 3 pieces of 40 watts UVC quartz lamps working at  $136 \mu\text{w}/\text{cm}^2$  intensity @ 1 meter
- ▶ LED indicates the working status of each UVC lamps
- ▶ Easy operation



Restaurant

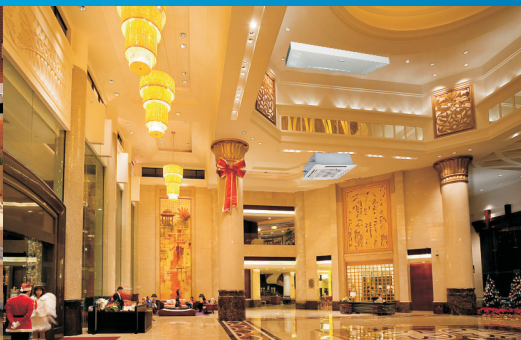

Hotel



Office



Hospital



Lab



Food processing plant

# MEDICAL GERMICIDAL AIR PURIFICATION SYSTEM



Model: Optimax 40 C

PURIFICATION MODULES					TECHNICAL PARAMETERS		
VOC/PCO + UVC	Intensity @ 1 meter	Rated Voltage (V)	Rated power (W)	Noise (dB)	Applicable area (ft <sup>2</sup> )	Weight (kg)	Produce size (mm)
40 watts x 3 pieces	( $136 \mu\text{w}/\text{cm}^2 \times 3$ )	230	130	<43	450 <small>(subjected to actual conditions on site)</small>	19	1200x600x80



## Structural Representation and Schematic Diagram

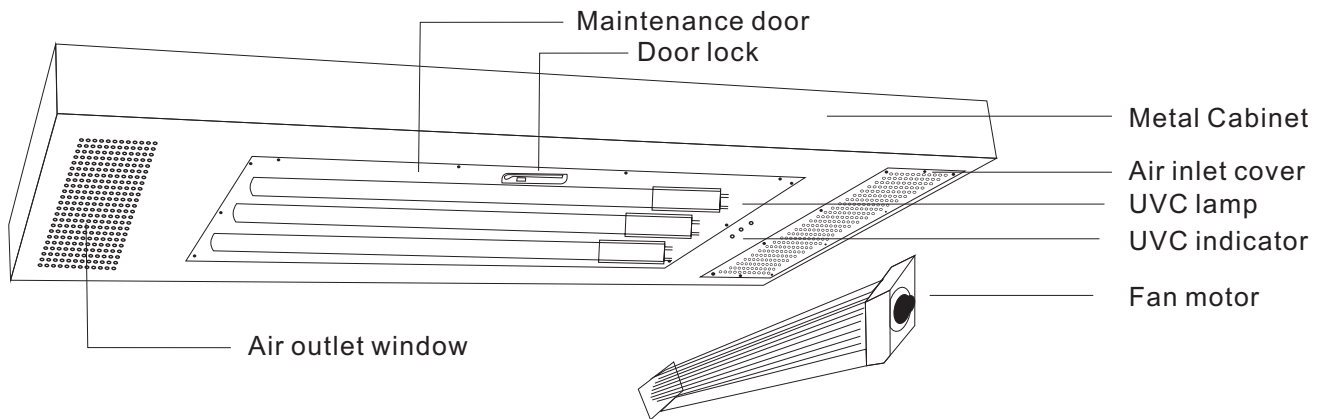

**Disease Protection** - Protects us from any airborne microorganisms such as bacteria, germs, viruses, molds, pollen etc by destroying the DNA's structure of microorganisms.

**Eliminate Odors** - It kills pathogens, germs, bacteria and molds that causes bad smell and makes the air in your rooms smell fresh and clean while producing ZERO ozone.

**Control Disease** - It helps stop the spread of disease and sicknesses for example Influenza, Tuberculosis, Allergies, etc. These include pathogens, disease causing viruses, fungi (mold) and bacteria.



## Contact details